

The Battery Isolation Manager isolates the two battery systems, Chassis & Coach, in a Motorhome. This prevents loads in one system from discharging both. It also connects the two battery systems together during charging. Both batteries are charged if either is being charged. The Coach Battery is charged while driving down the road, and the Chassis Battery is charged while plugged into Shore Power at a camp ground.

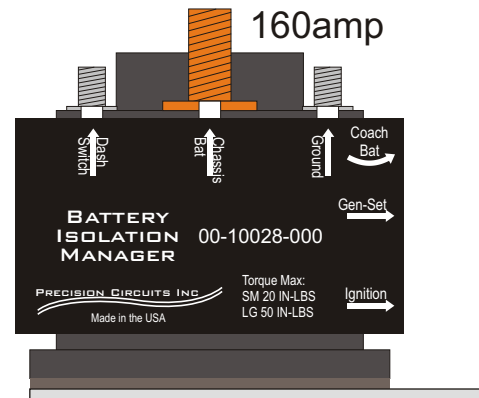
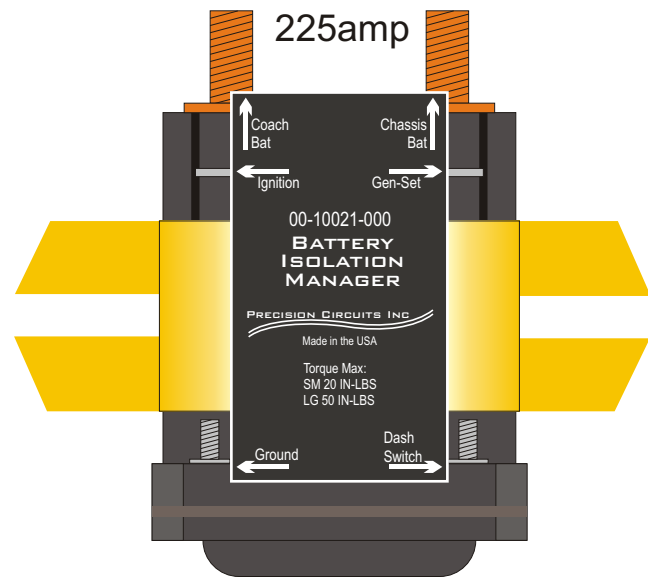

Key Features:

1. Integral to Isolator Relay
 - a. 160 & 225amp continuous models
 - b. Waterproof
IEC 60529, IP66 IP67,
ASTM B 117 96 Hours Salt Spray
 - c. Approved for Battery Compartments
2. Microprocessor based
 - a. Monitors battery state over longer periods of time
 - b. Not just simply voltage dependent
3. Charges
 - a. Coach Battery from Alternator
 - b. Chassis Battery from Coach Charger
4. Isolates Batteries to prevent discharging or overcharging of Batteries
5. Prevents
 - a. Equalization cycles from Damaging Chassis Battery
 - b. Annoying clicking of Isolator Relay
 - c. Overcharging of Coach Battery during long drives
 - d. Overcharging of Chassis Battery
 - e. Generator/Charger & Alternator Interference
6. Provides Emergency Start with Dash Switch
7. Runs Cooler using Less Power
 - a. 100°F cooler than competition
 - b. Uses only 4Watts of power versus 25W

Operation:

The **BATTERY ISOLATION MANAGER (BIM)** monitors the Battery Voltage of both the Chassis and Coach Batteries over long periods of time. If it senses a charging voltage, it connects the two batteries together. If the charging system is drastically overburdened, the batteries will be isolated, however, if the **BIM** sees a long term charging of both batteries it will allow the

batteries to remain connected and allow the charging system to do its job. Once the batteries have reached a Float Charge state for one hour, the **BIM** will isolate the batteries to prevent overcharging, and will only reconnect the batteries for charging if one of the Battery drops to approximately 80% charge, and the other is being charged. This long term monitoring of the batteries prevents the annoying relay clicking that exists in simpler Isolation Modules today.

Specifications:

Battery Isolation Manager

Part Number: 00-10021-000 00-10028-000

Relay Contacts: 225 Amps Continuous 160 Amps Continuous

Dimensions: 3-3/8" 4-1/8" 4-1/8" 3-1/8" 2-5/8" 3-7/8"
wide high deep wide high deep

Mounting Holes Two 1/4" wide slots

Connections Coach & Chassis Battery 5/16" Ring Terminal
Generator & Ignition 1/4" Faston, Quick Connect Terminal
Dash Switch & Ground #10 Ring Terminal

Environment:

Waterproof: IEC 60529, IP66 IP67, ASTM B 117 96 Hours Salt Spray

Dimensions: 3-3/8" wide, 4-1/8" high, 4-1/8" deep

	Minimum	Typical	Maximum
Volts DC	9.0VDC	12.0VDC	16.0VDC
Ambient Temperature	-40°C		+85°C

